

Produktbeschreibung:

Trägersäule teilbar zur Befestigung diverser Bauteile.

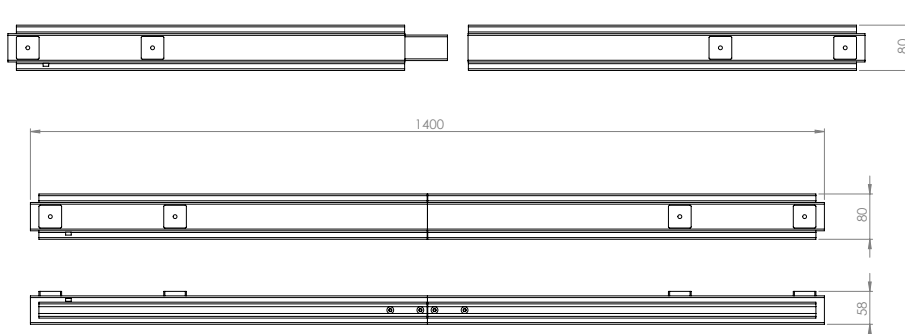

Technische Daten

Bestellnummer	10111039
Typenbezeichnung	eWork_TSG
Abmessung [H x B x T]	1400mm 80mm 58mm
Gewicht Netto	7,0 kg
Gewicht Versand	7,2 kg
Material	Stahl
max. Tragkraft	70,0 kg
Oberflächenbeschaffenheit	Pulverbeschichtet
Farbe	RAL 7016 Anthrazitgrau Struktur
Zubehör	2 x 10005590 Klemmhebel 1 x 10005617 Lamellenstopfen 8 x 10108427 Linsenschrauben M5x16

Montageort

EWorkSTATION	10108190 Fußgestell RAL 7016 10108752 Fußgestell RAL 9006 10108201 Winkel Trägersäule RAL 7016 10108758 Winkel Trägersäule RAL 9006
Montagetisch	10108201 Winkel Trägersäule » 10112057 Klemmbefestigung

